

# Container Loader System



High Speed Bulk Product Loading for ISO Containers

## Introduction

Members of the Schenck Process Group, Stock Redler Ltd are leading providers of feeding, automation and bulk solids handling solutions.

The Schenck Process Group are global market leaders of solutions in measuring and process technologies in industrial weighing, feeding, screening and automation. Close to the customer, with an unrivalled global network of operating companies we are your competent global partner for weighing, feeding, screening and automation solutions throughout the process industries.



## Typical Products Handled



Our philosophy is based on...

- ◆ Continuous product development
- ◆ Best practice approach to applications
- ◆ Raising industry standards



Capabilities

- ◆ Single Machine
- ◆ Multiple Machines
- ◆ System Solutions
- ◆ Installation & Commissioning
- ◆ Plant Layout & Integration
- ◆ Engineering & Contract Management
- ◆ Professional Customer Service Approach



Industries

- ◆ Power, Coal, Steel, Cement, Mineral Chemical, Grain Processing, Brewing/Malting Flour/Feed Food, Particle Board, Water Treatment

The Schenck Process Group develops, manufactures and markets a full range of solutions, products and turnkey systems on the basis of combining process engineering expertise, reliable components and field-proven technology.

Members of the Schenck Process Group are:



An extensive range of granular products can be handled by the Redler CLS. Typically these include –

- ◆ Plastic granules
- ◆ Chemical / fertilizer granules
- ◆ Wood pellets
- ◆ Grain
- ◆ Pellet feeds and meals
- ◆ Soya beans
- ◆ Refined sugar
- ◆ Rice

Demonstration machines are available to carry out trials on your products. Please contact Stock Redler Ltd to discuss your requirements.



### Product Shipping In Containers

The need to move bulk materials nationally and internationally is increasing as production operations consolidate and rationalise. To reduce shipping costs, logistics companies and manufacturers are making use of lined and unlined 20 and 40ft bulk containers for product transport.

Stock Redler Ltd has developed the Container Loader System based on over 80 years of material handling experience. Using the Redler® CLS allows customers to dramatically reduce shipping costs by eliminating transshipment at ports – bulk products can be delivered direct from production site to final destination using a globally cost effective method.

The Redler® CLS offers the following benefits:

- ❖ Supplied Ready To Go
- ❖ No modification required to existing outload facilities
- ❖ High loading capacity – in excess of 100 tonnes per hr
- ❖ Efficient filling profile gives maximum payloads
- ❖ Simple operation means minimal manpower requirements
- ❖ Low power consumption in operation
- ❖ Proven design means guaranteed performance

### Specification

#### Standard Specification

##### Thrower

- ❖ Robust mild steel fabricated frame.
- ❖ Chutes supplied with stainless steel product contact parts.
- ❖ Mild steel pulleys with shaft mounted in sealed for life bearings.
- ❖ Nylon idler discs.
- ❖ Black or white food grade rubber belt.
- ❖ 7.5 kW electric drive motor – 400V 3ph 50Hz (alternative voltages available).
- ❖ Totally enclosed Vee belt drive.
- ❖ Mild steel components are painted with two coats of high build anti-corrosive semi-gloss enamel (RAL5018) applied to a total of 80 microns dry film thickness.
- ❖ Stainless steel components are untreated self finish.

##### Support Frame

- ❖ Heavy duty construction fabricated from mild steel hollow section.
- ❖ Hand railing with spring loaded self closing gates.
- ❖ Non slip aluminium flooring.
- ❖ Twistlocks for secure connection to standard ISO container lugs.
- ❖ Mild steel components are painted with two coats of high build anti-corrosive semi-gloss enamel (RAL5018) applied to a total of 80 microns dry film thickness.

##### Controls

- ❖ The unit is supplied fully wired and ready to go.
- ❖ The control panel is provided with door mounted stop/start and easily accessible emergency stop buttons.
- ❖ A 10 metre cable and separate earth lead are provided for connection to the users supply point.

##### Mobile Access Stairs

- ❖ Mild steel fabricated construction with lightweight non-slip stair treads. Includes two fixed wheels and two manually operated locking wheels, handrailing and top platform access gate.
- ❖ Mild steel components are painted with two coats of high build anti-corrosive semi-gloss enamel (RAL5018) applied to a total of 80 microns dry film thickness.

##### Electrical Specification

The CLS can be supplied either as Standard or as ATEX Zone 22 Certified.

##### Optional Items

The following optional accessories are available for the CLS:

- ❖ Liner Inflation Fan and Seal Kit – standard unit or ATEX Zone 22 Certified.
- ❖ Extension Feed Shoe - for minimising product spillage when loading unlined containers.
- ❖ Additional Mobile Stair Unit

# The Redler® CLS Container Loading Made Simple...



Operation 1  
❖ The Liner is prepared



Operation 2  
❖ Container with empty liner fitted



Operation 3  
❖ The CLS is mounted on the container

## Design Features



**Throwing Belt**  
A robust endless rubber belt is rotated at high speed to ensure reliable high capacity product loading



**Safe Operation**  
The belt is automatically monitored for misalignment or slippage during operation to ensure safe operation



**Simple Mounting**  
The CLS is firmly secured to the standard ISO container mounting lugs by simple twist lock fixings

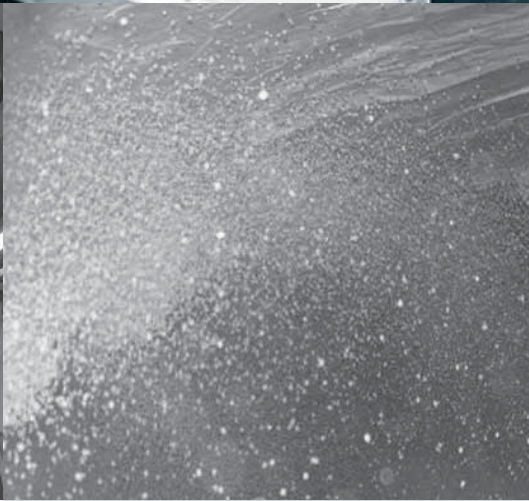
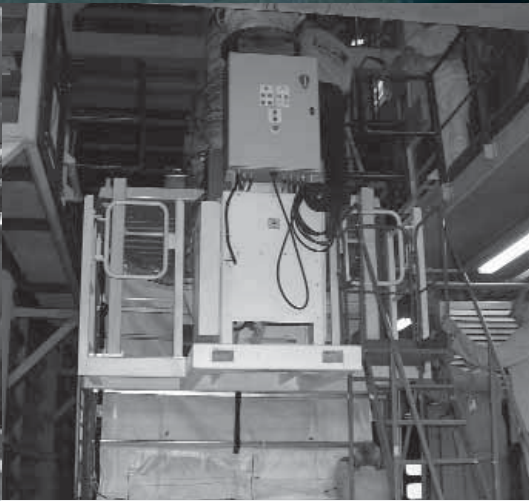

Operation 4

- ◆ Product feed and electrical connections are made

Operation 5

- ◆ The product is loaded into the container

Operation 6

- ◆ Loading complete – container ready to go

## The Container Loader Key Dimensions

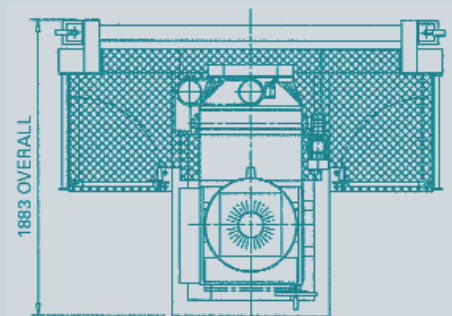
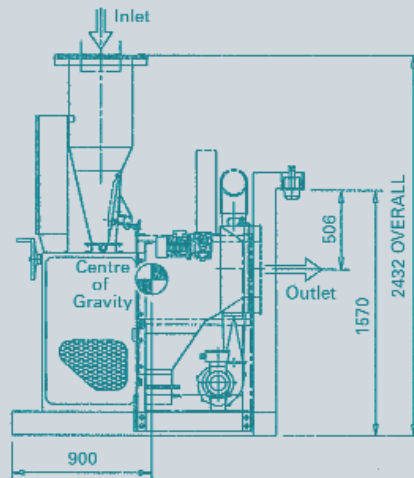
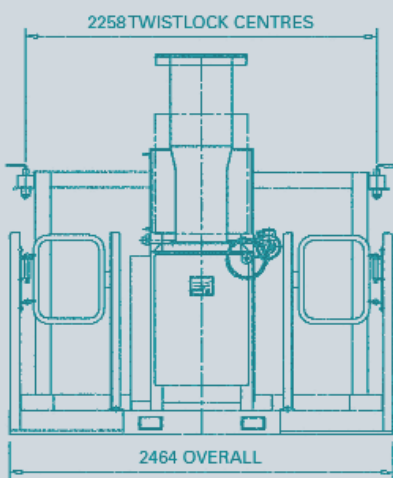

Quality & performance within your reach...

weighing

feeding

conveying

automation

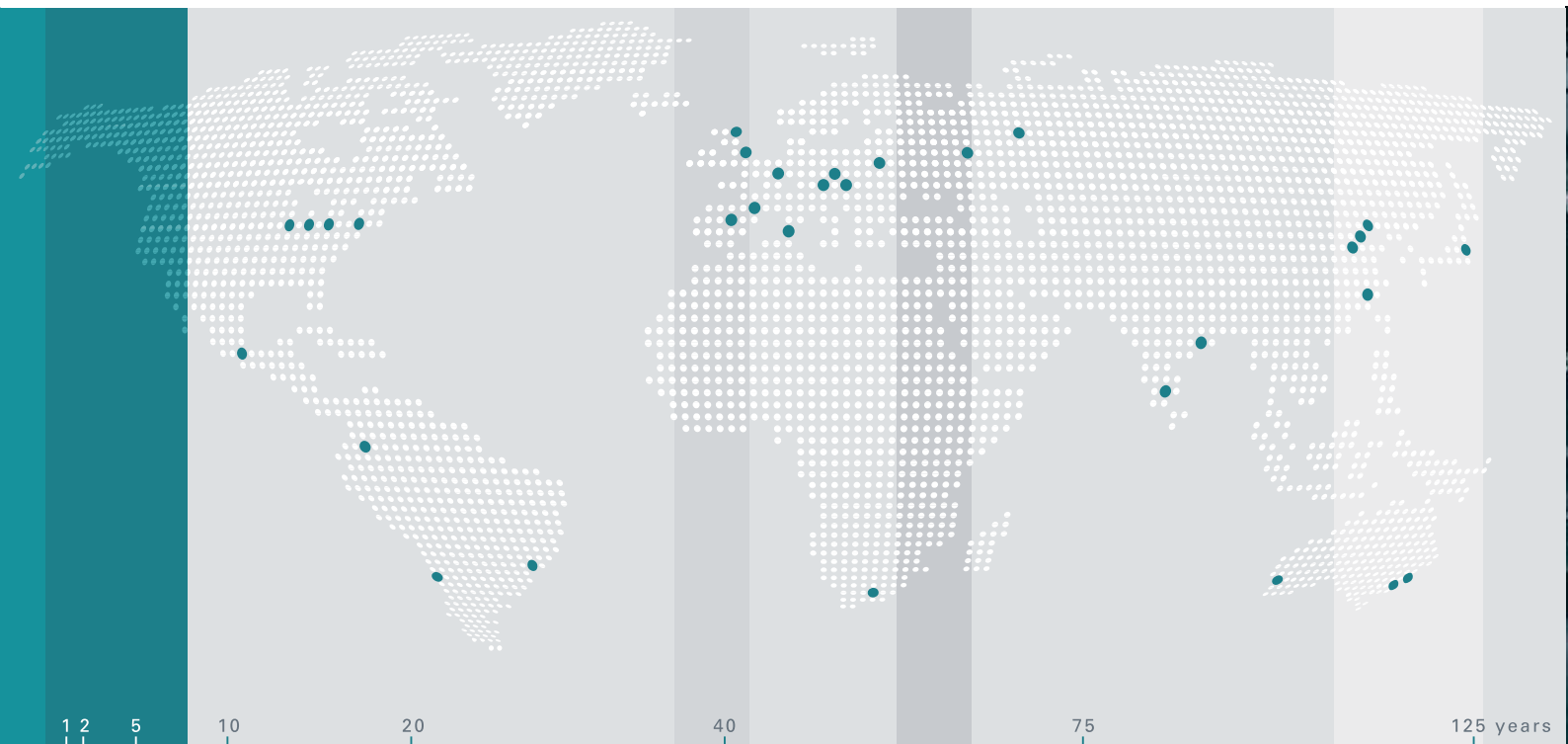

Stock Redler Limited  
Redler House  
Dudbridge, Stroud  
Gloucestershire  
GL5 3EY England  
T +44 (0) 1453 763 611  
F +44 (0) 1453 763 582  
sales@redler.com  
www.redler.com

Schenck Process GmbH  
Pallaswiesenstraße 100  
64293 Darmstadt  
Germany  
T +49 61 51-32 10 28  
F +49 61 51-32 11 72  
sales@schenckprocess.com



we make processes work